

8.8 Check points of inverter outdoor unit

(1) Models FDC400, 450KXZE2

● Check point of inverter outdoor unit (FDC400,450KXZE2)

▷ Check with power ON at the points marked with * . Check with 52C ON at the points marked with ★ .

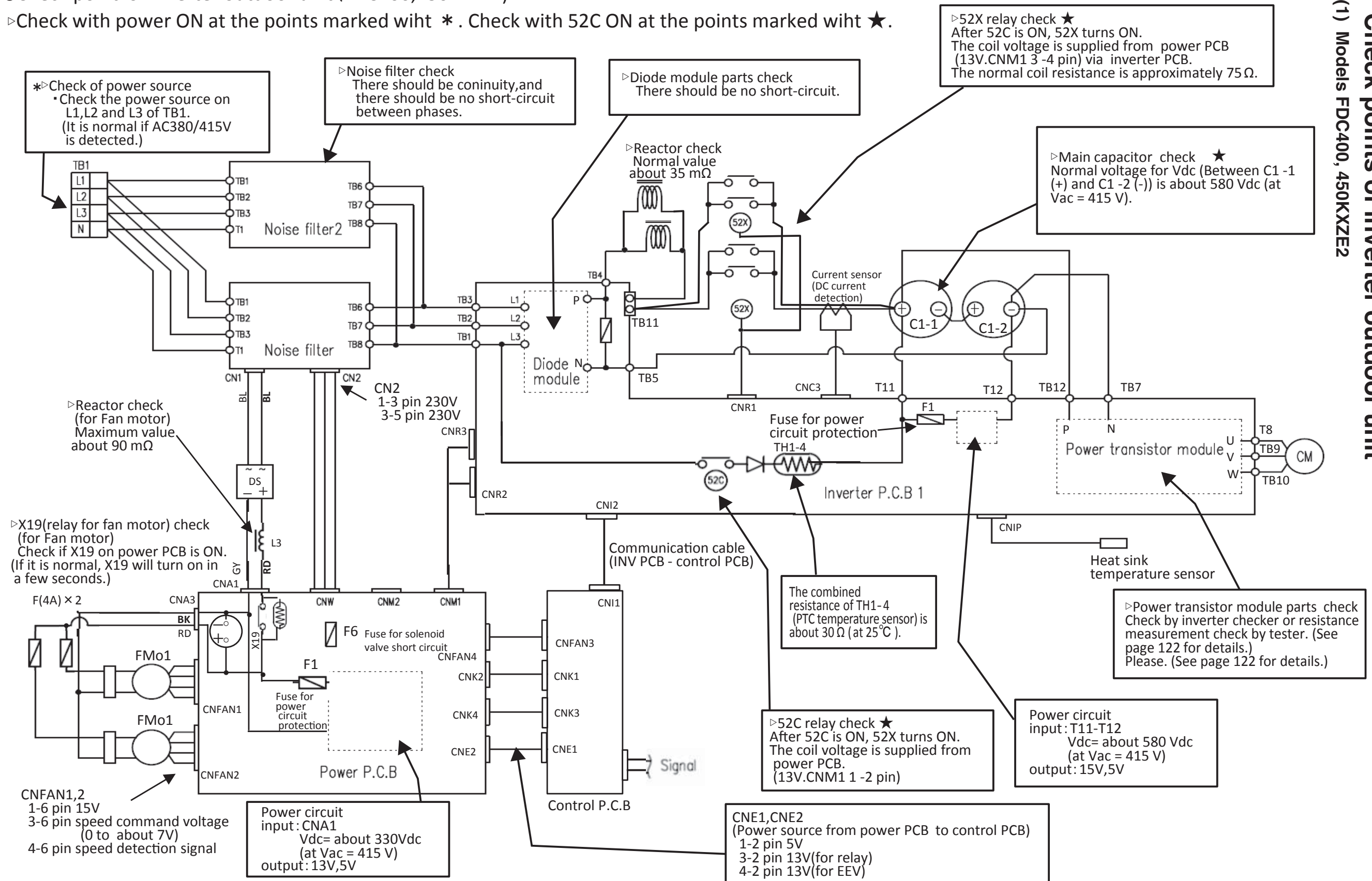

(2) Models FDC280-335KXZE2, 475-560KXZE2
(FDC280-335KXZE2 are 1 inverter system.)

● Check point of inverter outdoor unit (FDC475-560KXZE2.FDC280-335KXZE2 are 1 inverter system.)

▷ Check with power ON at the points marked with * . Check with 52C ON at the points marked with ★ .

